



## **ADDENDUM #2 NIB # 03-1718-10A**

### **THIS ADDENDUM INCLUDES REVISIONS TO THE RFP DOCUMENT:**

#### **1. Clarifications:**

- A. The majority of the KVCR staff will be relocated to an alternate location, however approximately 20 KVCR staff members will remain working in KVCR during construction. SBCCD and the KVCR staff will work with the selected General Contractor to shift staff locations within the building during construction to accommodate these people. The bid form 00 30 00 has been revised to include \$40,000 ALLOWANCE NO. 2 for developing a phasing plan and executing the work with staff in the building.
- B. An asbestos survey for the property is not required. This building was built in 2009/2010 as new construction and there's no hazmat concern

#### **2. Clarification on drawings:**

A note has been added on sheet A1.0 to patch and repair tile as necessary while adjusting the location of the toilet tissue dispenser.

Sheet A0.5 has been added to the set.

**END OF ADDENDUM #2 NARRATIVE**

**SECTION 00 30 01 – BID PROPOSAL FORM**

**PROPOSAL FOR: Construction Services for KVCR Radio and Television  
Building Repurpose, NIB #03-1718-10A**

**TO: San Bernardino Community College District, acting by and through its Governing Board, herein called "DISTRICT."**

**RE: (BIDDER):** \_\_\_\_\_

1. Pursuant to and in compliance with your Notice Inviting Bids and other documents relating thereto, the undersigned bidder, having familiarized himself with the terms of the contract, the local conditions affecting the performance of the contract and the cost of the work at the place where the work is to be done, hereby proposes and agrees to perform within the time stipulated, the contract, including all of its component parts, and everything required to be performed, including its acceptance by the DISTRICT, and to provide and furnish any and all labor, materials, tools, expendable equipment, utility and transportation services, and California sales and other applicable taxes, permits, licenses and fees required by the agencies with authority in the jurisdiction in which the work will be located necessary to perform the contract and complete all of the work in a workmanlike manner required in connection with the work required by this bid proposal, for the **KVCR Radio and Television Building Repurpose** in the DISTRICT described above, all in strict conformance with the drawings and other contract documents on file at the Purchasing Office of said DISTRICT for amounts set forth herein.
2. ADDENDA: The undersigned has thoroughly examined any and all Addenda (if any) issued during the bid period and are thoroughly familiar with all contents thereof and acknowledges receipt of the following Addenda: (Bidder to list all addenda).

ADDENDUM NO. \_\_\_\_\_

DATE RECEIVED \_\_\_\_\_

ADDENDUM NO. \_\_\_\_\_

DATE RECEIVED \_\_\_\_\_

ADDENDUM NO. \_\_\_\_\_

DATE RECEIVED \_\_\_\_\_

1. BASE BID

Base Bid shall include all costs required to perform the work as required by the contract documents and as may be expanded and/or reduced by Addenda.

The bidder agrees to perform all work required for this BID Proposal for the lump sum (turnkey) of:

*a. BASE BID:*

\_\_\_\_\_ Dollars

(In words printed or typed)

\$ \_\_\_\_\_ (In figures)

**b. BID ALLOWANCE:**

BID ALLOWANCE	DESCRIPTION	VALUE (\$)
ALLOWANCE NO. 01	Unforeseen Conditions and Not Included in the Scope of Work	\$50,000.00
ALLOWANCE NO. 02	Develop a Relocation Phasing Plan including moving services with KVCR and Execute the Work as Approved	\$40,000.00
Allowance Subtotal		<u>\$ 90,000.00</u>

Fifty Thousand Dollars

**c. TOTAL BID (Base Bid, and Bid Allowance):**

\_\_\_\_\_ Dollars  
 (In words printed or typed)

\$ \_\_\_\_\_ (In figures)

**d. ADDED BID ALTERNATES:**

BID ALTERNATES (Add): Bid alternates are ranked and prioritized based on the project needs.

ALTERNATE PRIORITY	TECHNICAL BID ALTERNATE	DESCRIPTION	ALTERNATE VALUE (\$)
<b>PRIORITY ORDER NO. 1</b>	<b>ADD BID ALTERNATE NO. 01</b>	Add new acoustic ceiling tiles in rooms MC158, MC171, and MC174 as shown in drawings	
<b>PRIORITY ORDER NO. 2</b>	<b>ADD BID ALTERNATE NO. 02</b>	Add LVT flooring in lobby MC 100 and hallway MC140 as shown in drawings	
<b>PRIORITY ORDER NO. 3</b>	<b>ADD BID ALTERNATE NO. 03</b>	Add prep and finish of existing concrete for new stain in Lobby MC 100, corridors MC140, MC162, MC144 soundlock, and portion of MC158 as shown in drawings. This would be done in place of 2 if budget allows.	
<b>PRIORITY ORDER NO. 4</b>	<b>ADD BID ALTERNATE NO. 04</b>	Add exterior window treatments as shown in drawings.	
<b>PRIORITY ORDER NO. 5</b>	<b>ADD BID ALTERNATE NO. 05</b>	Add new LVT flooring in Breakroom MC109 as shown in drawings.	

<b>PRIORITY ORDER NO. 6</b>	<b>ADD ALTERNATE NO. 06</b>	Add new breakroom MC109 paint and furniture as shown in drawings.
-----------------------------	-----------------------------	---

***e. DEDUCTIVE BID ALTERNATES:***

BID ALTERNATES (Subtract): Bid alternates are ranked and prioritized based on the project needs.

ALTERNATE PRIORITY	TECHNICAL BID ALTERNATE	DESCRIPTION	ALTERNATE VALUE (\$)
<b>PRIORITY ORDER NO. 1</b>	<b>SUBTRACT BID ALTERNATE NO. 01</b>	Deduct all changes to rooms MC143 and MC151	
<b>PRIORITY ORDER NO. 2</b>	<b>SUBTRACT BID ALTERNATE NO. 02</b>	Deduct all Greenroom MC147 flooring and paint	

***f. SUCCESSFUL BIDDER:***

- ❖ *If the vendor's bid price totaled in item c is lower than the district allocated budget for the project, then ignore item e (deductive alternates) completely. The district will start adding the bid alternates based on the priorities listed in item d. The lowest responsive and responsible bidder will be determined based on the more added alternates the district will receive and will be covered under the vendor's bid price.*
- ❖ *If the vendor's bid price totaled in item c is higher than the district allocated budget for the project, then skip item d (added alternates) completely to item e. The district will start deducting the bid alternates based on the priorities listed in item e. The lowest responsive and responsible bidder will be determined based on the lesser deductive alternates the district will receive and will be covered under the vendor's bid price.*

*Note: the district allocated budget will only be disclosed at the public bid opening date and time.*

2. The undersigned bidder shall be licensed and shall provide the following information:

Bidder's California Contractor's  
 License Number: \_\_\_\_\_  
 License expiration date: \_\_\_\_\_  
 Name on License: \_\_\_\_\_  
 Type of License: \_\_\_\_\_

If the bidder is a joint venture, each member of the joint venture must include the above information.

- 3. Attached is bid security in the amount of not less than ten percent (10%) of the bid: \$ \_\_\_\_\_. Bid bond, certified check, cashier's check, or cash. (circle one)
- 4. The names and contact information of all persons interested in the foregoing proposal as principals are as follows:

---

---

---

---

---

(IMPORTANT NOTICE: If bidder or other interested person is a corporation, state the legal name of such corporation, as well as the names of the president, secretary, treasurer, and manager thereof; if a co-partnership, state the true names of the firm, as well as the names of all individual co-partners comprising the firm; if bidder or other interested person is an individual, state the first and last names in full.)

5. Notice of Intent to Award Contract or other correspondence should be addressed to the undersigned at the address stated below.

---

---

---

---

---

6. ATTACHED TO THIS BID LETTER: Attached to this bid letter and by this reference incorporated herein and made a part of these completed Contract Bid Forms are:

<u>Name of Form/Document</u>	<u>Section Number</u>
<input type="checkbox"/> Bid Proposal Form	Section 00 30 01
<input type="checkbox"/> Bid Guarantee Form	Section 00 30 02
<input type="checkbox"/> Bid Bond (Notarized)	Section 00 30 03
<input type="checkbox"/> Designation of Subcontractors	Section 00 30 04
<input type="checkbox"/> Non-Collusion Declaration (Notarized)	Section 00 30 05
<input type="checkbox"/> Contractor's Certification Regarding Worker's Compensation	Section 00 30 06
<input type="checkbox"/> Prevailing Wages Certification	Section 00 30 07
<input type="checkbox"/> Acknowledgement of Bidding Practices Regarding Indemnity	Section 00 30 08
<input type="checkbox"/> Bidder's Acknowledgement of Project Duration	Section 00 30 09
<input type="checkbox"/> Site Visit Certification	Section 00 30 10

7. **TIME FOR COMPLETION:** The DISTRICT may give a notice to proceed within thirty (30) days of the award of the bid by the DISTRICT. Once the CONTRACTOR has received the notice to proceed, the CONTRACTOR shall complete the work in the time specified in the Agreement.

In the event that the DISTRICT desires to postpone giving the notice to proceed beyond this thirty (30) day period, it is expressly understood that with reasonable notice to the CONTRACTOR, the DISTRICT may postpone giving the notice to proceed. It is further expressly understood by the CONTRACTOR, that the CONTRACTOR shall not be entitled to any claim of additional compensation as a result of the postponement of giving the notice to proceed.

If the CONTRACTOR believes that a postponement will cause a hardship to it, the CONTRACTOR may terminate the contract with written notice to the DISTRICT within ten (10) days after receipt by the CONTRACTOR of the DISTRICT's notice of postponement. It is further understood by the CONTRACTOR that in the event that the CONTRACTOR terminates the Contract as a result of postponement by the DISTRICT, the DISTRICT shall only be obligated to pay the CONTRACTOR for work performed by the CONTRACTOR at the time of notification of postponement. Should the CONTRACTOR terminate the contract as a result of a notice of postponement, the DISTRICT shall have the authority to award the contract to the next lowest responsible bidder.

8. It is understood that the DISTRICT reserves the right to reject any or all bids and/or waive any irregularities or informalities in this bid or in the bid process. The CONTRACTOR understands that it may not withdraw this bid for a period of sixty (60) days after the date set for the opening of bids.
9. The required List of designated subcontractors is attached hereto.
10. The required notarization: Bid Bond and the Non-Collusion Declarations for CONTRACTOR, *and the Non-Collusion Declarations for* subcontractors are attached hereto.
11. It is understood and agreed that if written notice of the acceptance of this bid is mailed, telegraphed, or delivered to the undersigned after the opening of the bid, and within the time this bid is required to remain open, or at any time thereafter before this bid is withdrawn, the undersigned will execute and deliver to the DISTRICT a contract in the form attached hereto in accordance with the bid as accepted and prepared by Owner, and that he will also furnish and deliver to the DISTRICT the Performance Bond and Payment Bond, all within ten (10) calendar days after receipt of notification of award, and that the work under the contract shall be commenced by the undersigned bidder, if awarded the contract, by the start date provided in the DISTRICT's Notice to Proceed, and shall be completed by the CONTRACTOR in the time specified in the contract documents.
12. Time is of the essence regarding this contract, therefore, in the event the bidder to whom the Notice of Intent to Award Contract is given fails or refuses to post the required bonds and return executed copies of the Agreement form within ten (10) calendar days from the date of receiving the Notice of Intent to Award Contract, the DISTRICT may declare the bidder's bid deposit or bond forfeited as damages.
13. Pursuant to Government Code section 4552, in submitting a bid to the DISTRICT, the bidder offers and agrees that if the bid is accepted, it will assign to the DISTRICT all rights, title, and interest in, and to all causes of action it may have under section 4 of the Clayton Act (15 U.S.C. § 15) or under the Cartwright Act (Business and Professions Code sections 16700, *et. seq.*), arising from the purchase of goods, materials, or services by the bidder for sale to the DISTRICT pursuant to the bid. Such assignment shall be made and become effective at the time the DISTRICT tenders final payment to the bidder.
14. The bidder declares that he/she has carefully examined the location of the proposed work, that he/she has examined the Plans, General Conditions of the contract, Supplemental Conditions of the contract, and

Specifications, and read the accompanying instructions to bidders, and hereby proposes and agrees, if this proposal is accepted, to furnish all materials and do all work required to complete the said work in accordance with the Plans, General Conditions of the contract, Supplementary Conditions of the contract, and Specifications, in the time and manner therein prescribed for the unit cost and lump sum amounts set forth in this Bid Form.

15. In the event of ambiguity due to a conflict between words and numbers with respect to the amount of the bid, words shall govern over numbers.
16. The bidder is familiar with Government Code sections 12650, et. seq., and Penal Code section 72 and understands that false claims can lead to imprisonment.
17. The bidder acknowledges that that they have reviewed the work outlined in the contract documents and fully understands the Scope of work required in the Proposal, and further acknowledges that this proposal includes the scope of work within this Bid Proposal. It is further understood that no exceptions, exclusions, or clarifications will be considered.
18. The undersigned has notified the District through the Project Manager of any discrepancies or omissions, or of any doubt about the meaning of any of the Contract Documents, and has contacted the District before bid date to verify the issuing of any clarifying Addenda.

I, the below-indicated bidder, declare under penalty of perjury that the information provided and representations made in this bid are true and correct.

---

Proper Name of Bidder

---

Address

By: \_\_\_\_\_  
Signature of Bidder

Date: \_\_\_\_\_

Corporate Seal:  
(If Corporation)

**NOTE:** *If bidder is a corporation, the legal name of the corporation shall be set forth above together with the signature of authorized officers or agents and the document shall bear the corporate seal; if bidder is a partnership, the true name of the firm shall be set forth above, together with the signature of the partner or partners authorized to sign contracts on behalf of the partnership; and if bidder is an individual, his signature shall be placed above.*

**All signatures must be made in permanent blue ink**

**END OF SECTION**

**LIFE SAFETY PLAN NOTES**

- A. LIFE SAFETY NOTES APPLY TO ALL SHEETS
- B. LIFE SAFETY PLAN IS BASED ON A# 04-109146
- C. AREA OF SCOPE OF WORK MODIFYING ONLY THE (E) PLAN ON BROADCAST SPACE MC 173 AND STUDIO AND AUDIO CONTROL SPACES MC 143 & MC 151. OVERALL OCCUPANCY TO REMAIN AS #04-109146.
- D. ALL SPACES TO REMAIN WITH SAME OCCUPANCY TYPE AS SHOWN UNDER CODE ANALYSIS BELOW FROM #04-109146.
- E. ALL OCCUPANCY CALCULATIONS ARE REMAINING AS # 04-109146.
- F. PLUMBING CALCULATIONS REMAINING FROM #04-109146.
- G. ALL (E) DOOR SIGNAGE TO REMAIN.
- H. ALL (E) DOORS TO COMPLY WITH CBC SECTION 11B-404.2.3. a. CLOSER TO BE ADJUSTED AS REQUIRED TO COMPLY WITH 5 POUNDS MAX. PRESSURE.

DSA SUBMITTAL



LIFE SAFETY AND CODE ANALYSIS  
MEDIA COMMUNICATIONS BUILDING REMODEL

**0.50**  
75-18888-00  
1/22/2018  
REVISED

701 S. MOUNT VERNON AVE  
SAN BERNARDINO, CA 92410

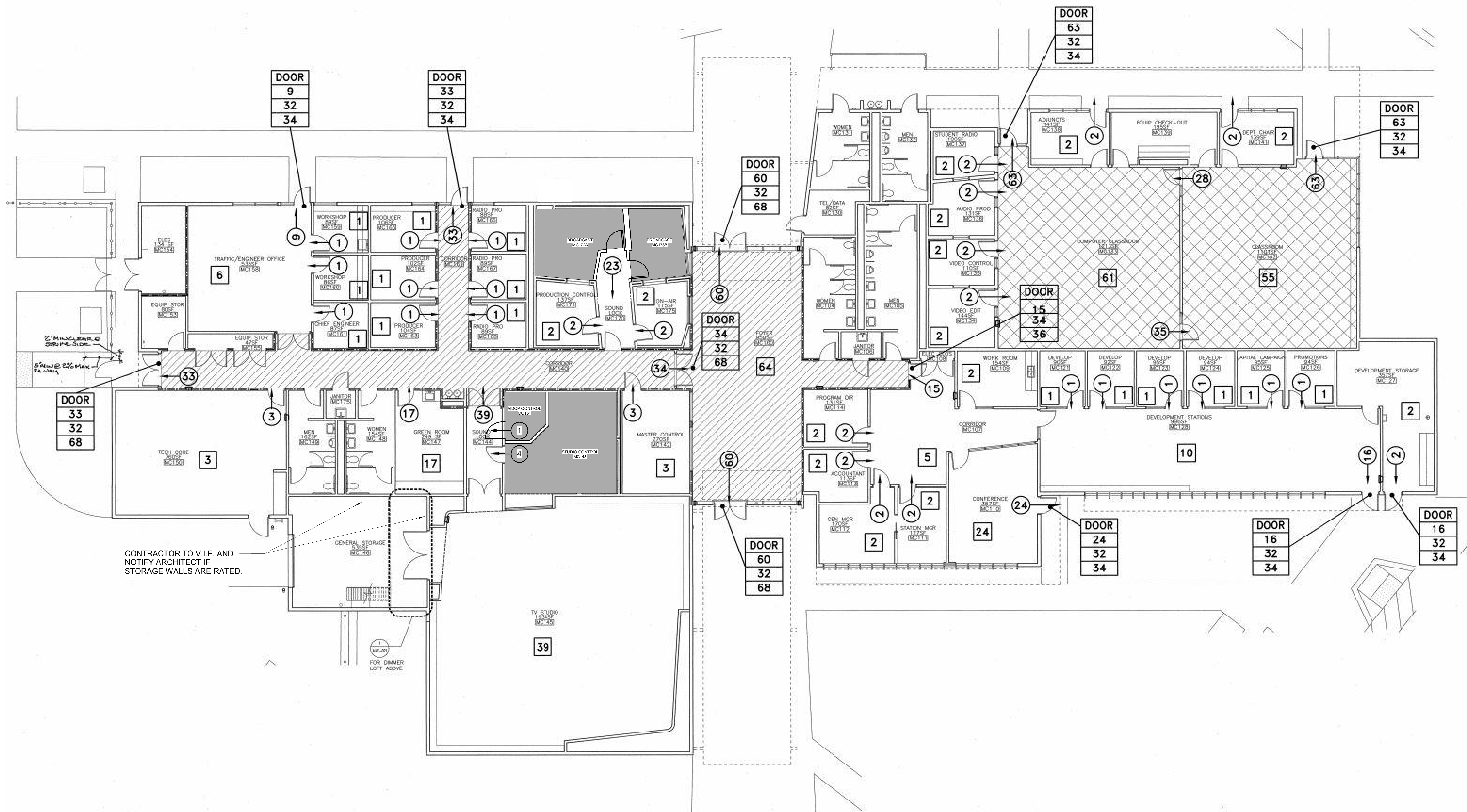

**1 FLOOR PLAN**  
1/8" = 1'-0"

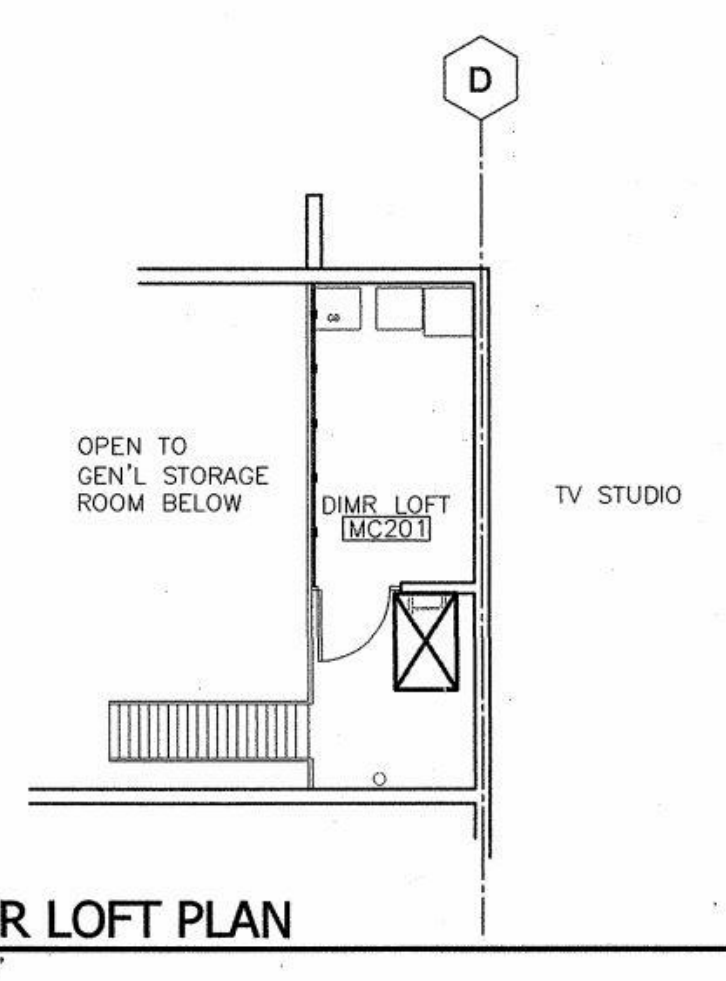

**2 DIMMER LOFT PLAN**  
1/8" = 1'-0"

**LEGEND**

**OCCUPANT LOAD FACTORS**

CLASSROOM	SF/PERSON	20
OFFICE/ADMIN		100
STORAGE/CLOSET		300
LOUNGE/MEETING		15
VOCATIONAL		50
FOYER (OFFICE)		15

- - - EXIT COMPONENT  
 - - - OCCUPANT LOAD  
 - - - REQUIRED EXIT WIDTH (INCHES)  
 - - - PROVIDED EXIT WIDTH (INCHES)

# OCCUPANT LOAD  
 # OCCUPANT LOAD USING EXIT-ACCESS OR EXIT.

□ 'B' OCCUPANCY (E spaces)  
 ▨ 'A-3' OCCUPANCY (E spaces)  
 ▩ 1-HOUR CORRIDOR (E spaces)  
 ■ 1-HOUR FIRE RESISTIVE WALL (E) "B" OCCUPANCY spaces affected

**NOTE**

**PLUMBING FIXTURES**

PER CPC 4.1 - COLLEGES & UNIVERSITIES

FIXTURE TYPE	MEN		WOMEN	
	REQ.	PROVIDED	REQ.	PROVIDED
WATER CLOSET	5	6	7	7
URINAL	5	5		
LAVATORY	5	5	5	6



CONSTRUCTION PLAN NOTES

- A. CONSTRUCTION NOTES APPLY TO ALL SHEETS.
- B. ALL DIMENSIONS ARE ACTUAL AND ARE TO FACE OF FINISHED WALL, UNLESS NOTED OTHERWISE.
- C. GYPSUM BOARD AND PLASTER SURFACES SHALL BE ISOLATED WITH CONTROL JOINTS WHERE REQUIRED. GC TO NOTIFY DLR GROUP OF LOCATIONS PRIOR TO CONSTRUCTION.
- D. GENERAL CONTRACTOR SHALL FURNISH AND INSTALL 2" X 10" CONTINUOUS FIRE RETARDANT TREATED WOOD BLOCKING OR 10" WIDE SHEET METAL BACKING IN STEEL STUD PARTITIONS FOR PROPER ANCHORAGE OF WALL ATTACHED ITEMS INCLUDING BUT NOT LIMITED TO THE FOLLOWING: GRAB BARS, CASEWORK, MILLWORK, TOILET ACCESSORIES, TOILET PARTITIONS, WALL MOUNTED FIXTURES, MARKER BOARDS, TACK BOARDS, DOOR STOPS, AUDIO VISUAL BRACKETS, ETC.
- E. WALLS OF FIRE-RESISTANCE RATED CONSTRUCTION SHALL EXTEND TO UNDERSIDE OF FLOOR OR ROOF DECK ABOVE.
- F. SEAL PENETRATIONS THROUGH FIRE-RESISTANCE RATED CONSTRUCTION WITH THROUGH-PENETRATION FIRESTOP MATERIAL AS REQUIRED TO ACHIEVE RESPECTIVE FIRE-RESISTIVE RATING AND SMOKE STOPPAGE.
- G. INCLUDE OWNER-FURNISHED AND INSTALLED ITEMS AND OWNER FURNISHED AND CONTRACTOR INSTALLED ITEMS IN THE CONSTRUCTION SCHEDULE, AND COORDINATE WITH OWNER TO ACCOMMODATE THESE ITEMS.
- H. SEE ENLARGED PLAN FOR EXTENTS OF DEMOLITION.
- I. REFER TO DETAIL 910.20 FOR DOOR CLEARANCE INFORMATION.
- J. FOR INTERIOR ELEVATION MOUNTING HEIGHT INFORMATION REFERENCE 10.22.
- K. FOR EXISTING RATED WALLS REFER TO 0.50

CONSTRUCTION PLAN LEGEND

- NEW FULL HEIGHT PARTITION. REFER TO ENLARGED PLANS IN A7 SERIES FOR WALL TYPE. REFER TO A8.1 FOR WALL TYPES.
- EXISTING PARTITION TO REMAIN
- SWING DOOR IDENTIFIER. SEE DOOR SCHEDULE SHEET A.9.1.
- EXISTING MILLWORK TO REMAIN
- NEW MILLWORK: SEE DETAILS 22-25/A8.1
- EXISTING MILLWORK TO BE DEMOLISHED
- EXISTING COLUMN TO REMAIN
- SHADING AREA NOT IN CONTRACT (NIC)
- (N) NEW
- (E) EXISTING
- MATERIAL FINISH TAG. SEE A4.1 FOR MORE INFORMATION.

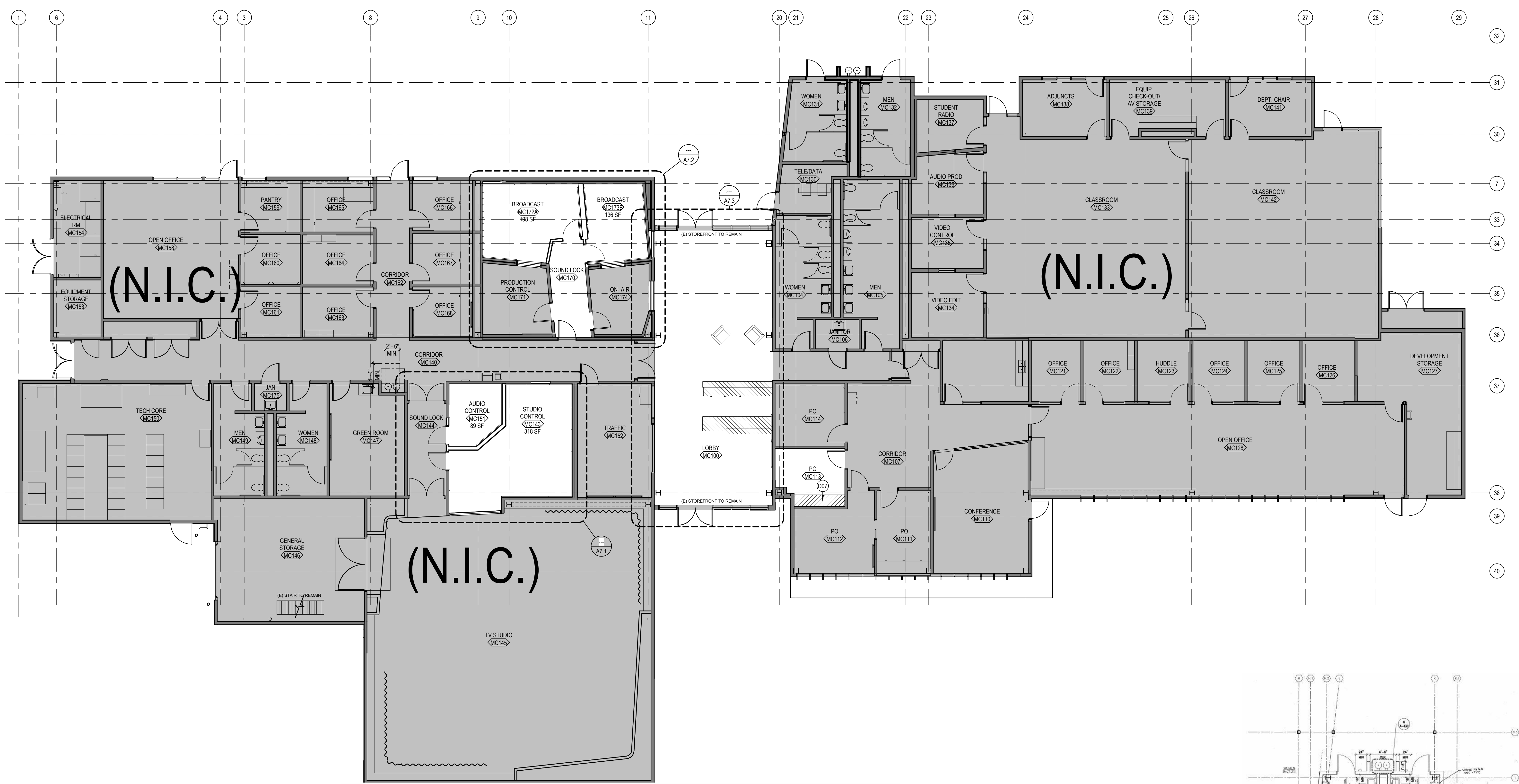

CONSTRUCTION PLAN  
SCALE: 1/8" = 1'-0"

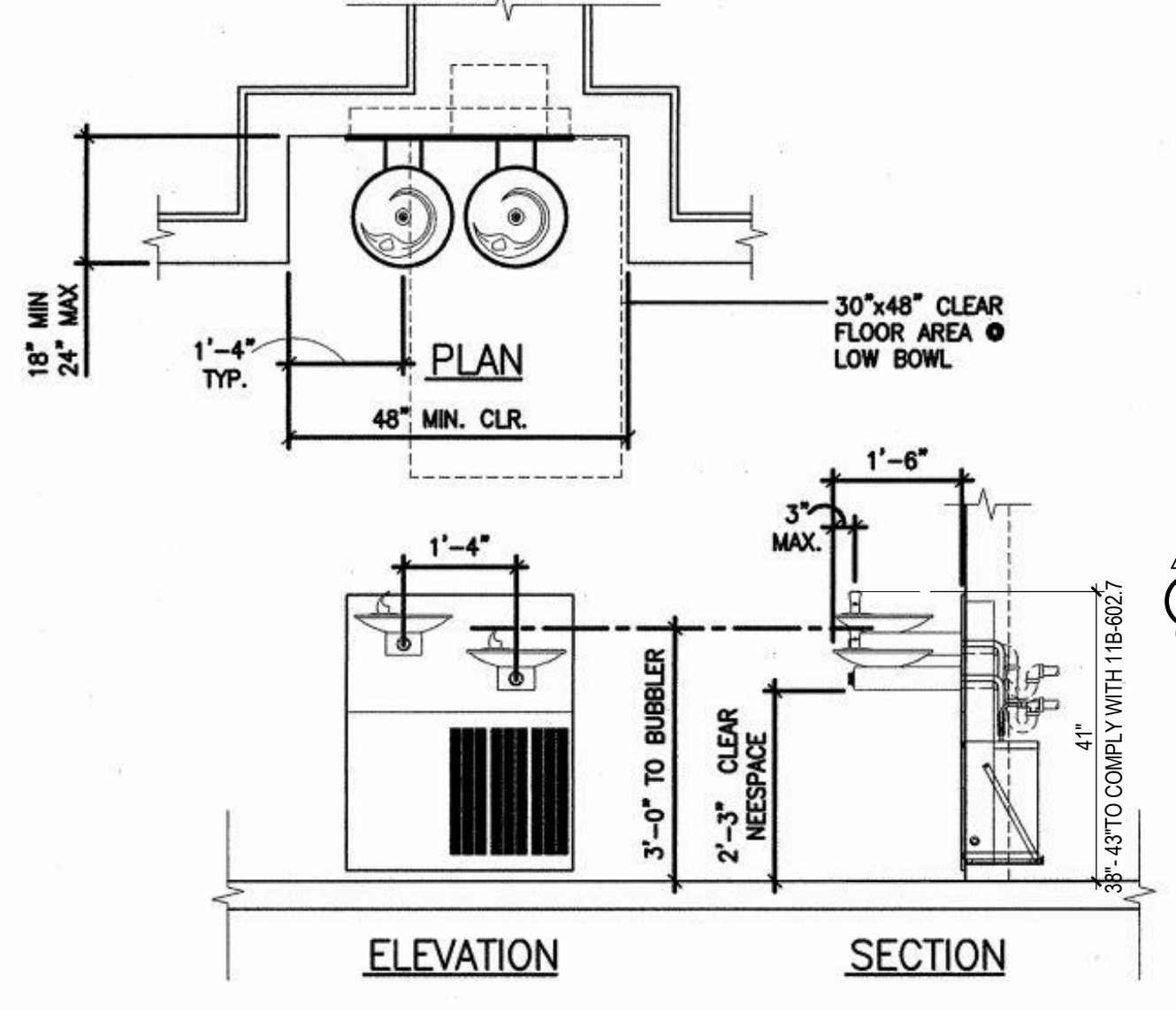

(E) DRINKING FOUNTAIN DETAIL  
SCALE: 1/2" = 1'-0"

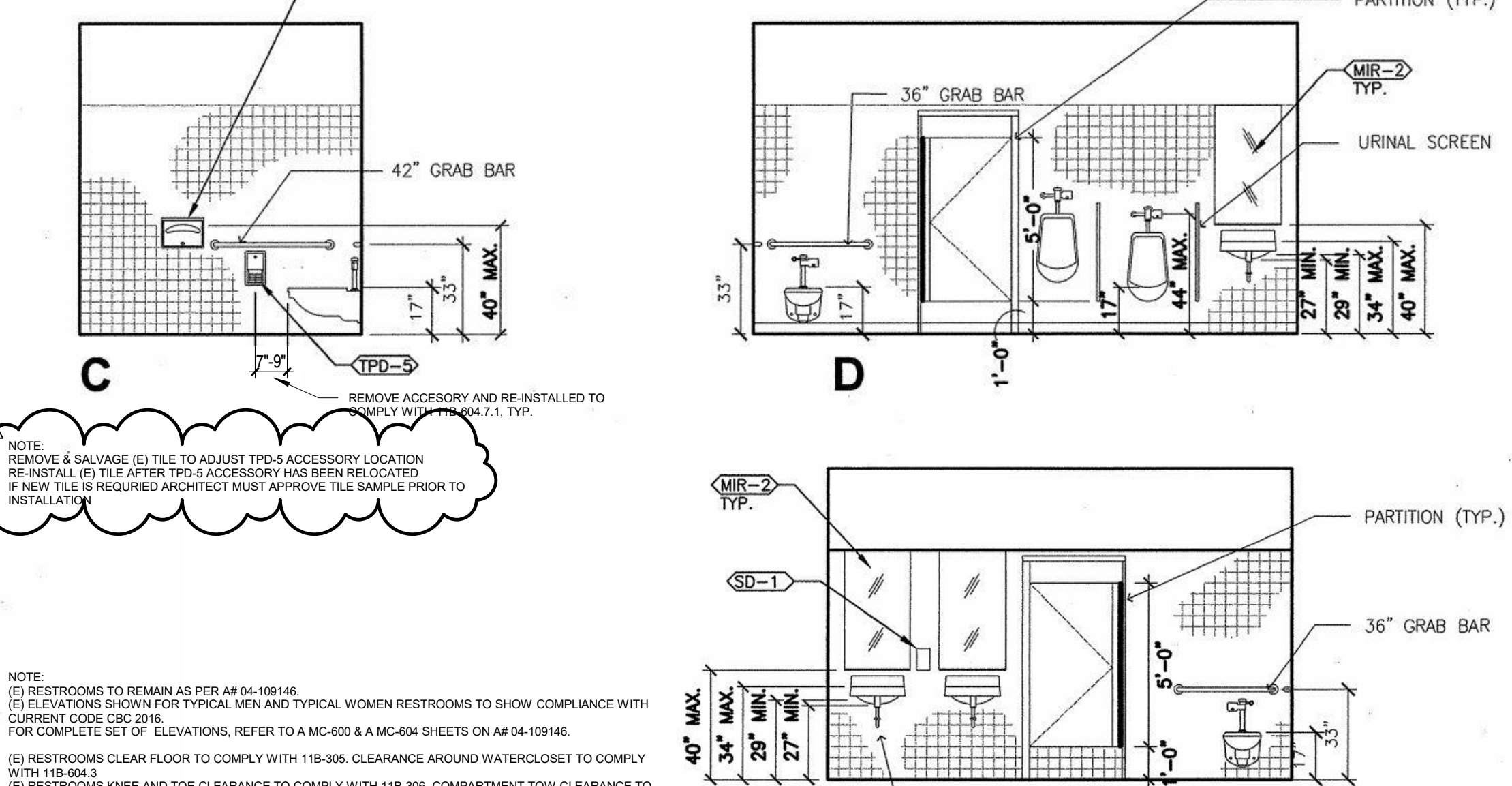

(E) BATHROOM TYPICAL ELEVATIONS FOR MEN AND WOMEN  
SCALE: 1/4" = 1'-0"

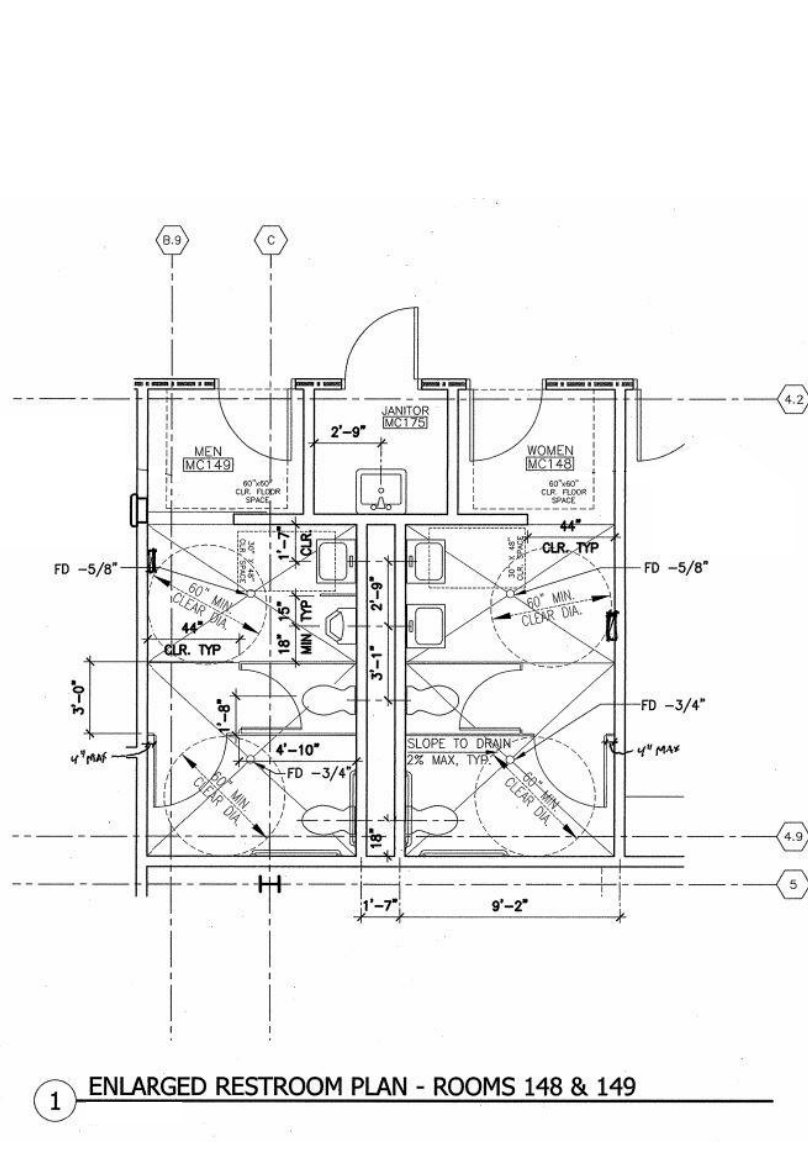

(E) BATHROOM PLANS  
SCALE: 1/8" = 1'-0"

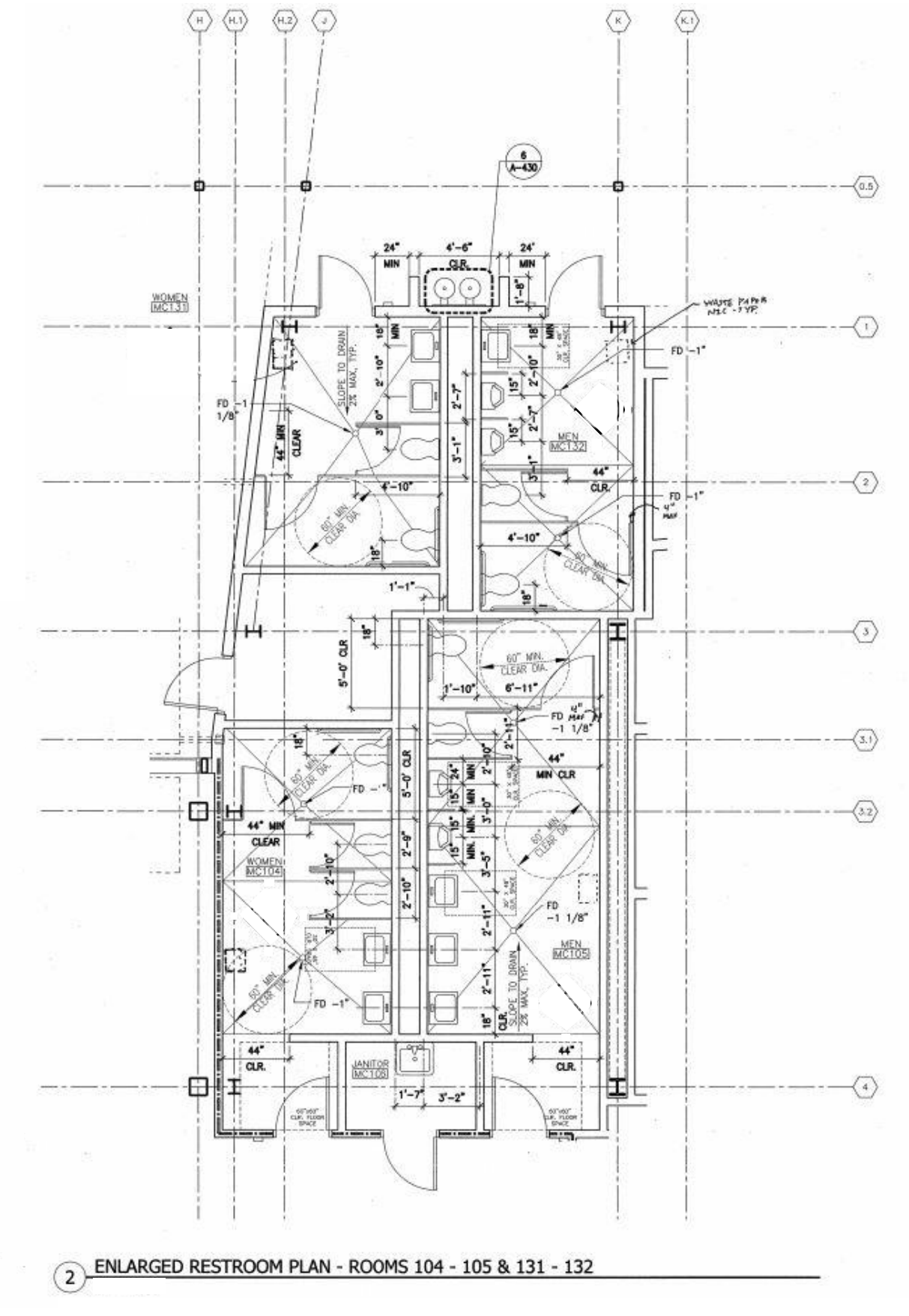

(E) BATHROOM PLANS  
SCALE: 1/8" = 1'-0"

**END OF ADDENDUM #2**